

INTIMA

Market leading feminine hygiene unit



INTIMA was developed in response to market demand for an aesthetically pleasing, robust and serviceable feminine hygiene unit. In just a short length of time Kennedy's INTIMA has become the market leading feminine hygiene unit.

The unit provides a large 23 litres (15 litre unit also available) waste holding capacity in a sleek, modern and compact design with minimal floor obstruction. INTIMA can be used for liner and bin exchange service and embodies exceptional functionality, quality and unique service friendly features. It is available in manual, foot pedal and electronic no-touch versions and across Kennedy's full range of finishes.



Finishes available

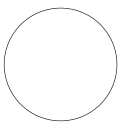

Classic White

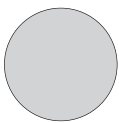

Functional Grey

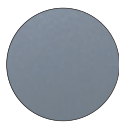

Designer Grey



Premium Satin Chrome

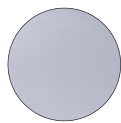

Premium Bright Chrome

Benefits

Ease of service

- > Innovative reversible cover* eases location in cubicle
- > Designed throughout to minimise dirt traps
- > Flexible liner system* for easy liner fitting

Maximum hygiene

- > Foot pedal/electronic no-touch models for hands-free operation
- > Snap in/out protective flap inset
 - Protects against soiling
 - Aids super fast and hygienic service

For extra hygiene

- > Reinforced drawstring "easy closing" bin liners
- > Germicidal powder sachets

For more information
www.kennedy-hygiene.co.uk

INTIMA

Market leading feminine hygiene unit



Packaging info

	Plt.Type	Packed	Qty Per	Weight/Kg	Measurement in cm
Intima Pedal (all finishes)		Carton	2	6.85	54 x 29 x 49
	Euro Plt.	Pallet	48	181	120 x 80 x 209
Intima Manual (all finishes)		Carton	2	6.2	54 x 29 x 49
	Euro Plt.	Pallet	48	167	120 x 80 x 209
Intima Auto (all finishes)		Carton	2	7.35	50 x 34 x 56
	Euro Plt.	Pallet	40	139	120 x 80 x 223

Technical drawings

Materials: Constructed predominantly from ABS. Dispenser can be recycled or disposed of in accordance with local regulations.

Packing: Assembled units packed in polythene bags, two in a carton.

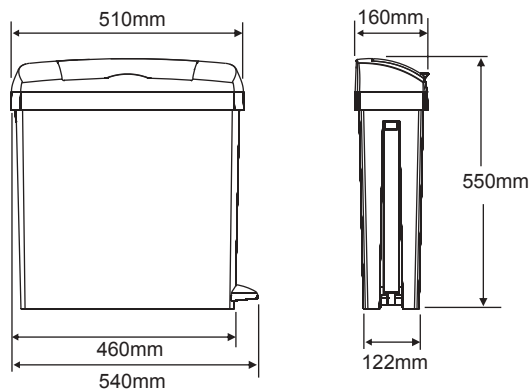

Consumables

Reinforced drawstring "easy closing" bin liners

- > Robust 70 microns thick bags
- > Unbreakable drawstring

Germicidal powder sachets

- > Inhibit microbial growth
- > Prevents offensive odour

Snap in/out protective flap inset

- > Protects against soiling
- > Aids super fast and hygienic service

Kennedy Hygiene Products Limited

Brookside

Uckfield

East Sussex TN22 1YA

United Kingdom

T +44 (0) 1825 768141

F +44 (0) 1825 768143

E sales@kennedy-hygiene.com

